

DRAINAGE, EROSION, AND SEDIMENT CONTROL (DESC) GENERAL NOTES

1. THE DOUGLAS COUNTY DEVELOPMENT REVIEW ENGINEER'S SIGNATURE AFFIXED TO THIS DOCUMENT INDICATES THE DOUGLAS COUNTY ENGINEERING DIVISION HAS REVIEWED THE DOCUMENT AND FOUND IT IN GENERAL COMPLIANCE WITH THE DOUGLAS COUNTY SUBDIVISION REGULATIONS AND/OR THE GRADING, EROSION AND SEDIMENT CONTROL (GESC) CRITERIA MANUAL. THE DOUGLAS COUNTY ENGINEER, THROUGH ACCEPTANCE OF THIS DOCUMENT, ASSUMES NO RESPONSIBILITY (OTHER THAN AS STATED ABOVE) FOR THE COMPLETENESS AND/OR ACCURACY OF THESE DOCUMENTS.
2. THE ADEQUACY OF THIS DESC PLAN LIES WITH THE ORIGINAL DESIGNER.
3. THE DESC PLAN SHALL BE CONSIDERED VALID FOR TWO (2) YEARS FROM THE DATE OF ACCEPTANCE BY DOUGLAS COUNTY, AFTER WHICH TIME THE PLAN SHALL BE VOID AND WILL BE SUBJECT TO RE-REVIEW AND RE-ACCEPTANCE BY DOUGLAS COUNTY.
4. ALL MATERIALS AND WORKMANSHIP SHALL BE SUBJECT TO INSPECTION BY THE DOUGLAS COUNTY ENGINEERING DIVISION. DOUGLAS COUNTY RESERVES THE RIGHT TO ACCEPT OR REJECT ANY SUCH MATERIALS AND WORKMANSHIP THAT DOES NOT CONFORM TO THE GESC MANUAL, DESC PLAN OR DESC PERMIT.
5. THE PLACEMENT OF EROSION AND SEDIMENT CONTROL BEST MANAGEMENT PRACTICES (BMPs) SHALL BE IN ACCORDANCE WITH THE DOUGLAS COUNTY ACCEPTED DESC PLAN AND THE DOUGLAS COUNTY GESC MANUAL, AS AMENDED.
6. ANY VARIATION IN MATERIAL, TYPE OR LOCATION OF EROSION AND SEDIMENT CONTROL BMPs FROM THE DOUGLAS COUNTY ACCEPTED DESC PLAN WILL REQUIRE APPROVAL FROM AN ACCOUNTABLE REPRESENTATIVE OF THE DOUGLAS COUNTY ENGINEERING DIVISION.
7. AFTER THE DESC PLAN HAS BEEN ACCEPTED, THE DESC PERMIT APPLIED FOR AND FEES SUBMITTED TO THE COUNTY, AND THE DESC PLAN/DESC PLAN STANDARD NOTES AND DETAILS OBTAINED AND REVIEWED, THE CONTRACTOR MAY INSTALL THE INITIAL-STAGE EROSION AND SEDIMENT CONTROL BMPs INDICATED ON THE ACCEPTED DESC PLAN.
8. THE FIRST BMP TO BE INSTALLED ON THE SITE SHALL BE CONSTRUCTION FENCE, MARKERS, OR OTHER APPROVED MEANS OF DEFINING THE LIMITS OF CONSTRUCTION, INCLUDING CONSTRUCTION LIMITS ADJACENT TO STREAM CORRIDORS AND OTHER AREAS TO BE PRESERVED.
9. AFTER INSTALLATION OF THE INITIAL-STAGE EROSION AND SEDIMENT CONTROL BMPs, THE PERMITTEE SHALL CALL THE DOUGLAS COUNTY ENGINEERING PERMITS STAFF AT 303-660-7487 TO SCHEDULE A PRECONSTRUCTION MEETING AT THE PROJECT SITE. THE REQUEST SHALL BE MADE A MINIMUM OF THREE BUSINESS DAYS PRIOR TO THE REQUESTED MEETING TIME. NO CONSTRUCTION ACTIVITIES SHALL BE PLANNED WITHIN 24 HOURS AFTER THE PRECONSTRUCTION MEETING, UNLESS A PRECONSTRUCTION MEETING RELEASE FROM HAS BEEN ISSUED.
10. THE DESC MANAGER MUST ATTEND THE PRECONSTRUCTION MEETING. IF THE INSTALLATION OF THE INITIAL BMPs ARE NOT APPROVED BY THE DOUGLAS COUNTY EROSION CONTROL INSPECTOR, THE APPLICANT WILL HAVE TO PAY A REINSPECTION FEE, ADDRESS ANY PROBLEMS WITH BMP INSTALLATION, AND CALL TO RESCHEDULE THE MEETING, WITH A CORRESPONDING DELAY IN THE START OF CONSTRUCTION.
11. CONSTRUCTION SHALL NOT BEGIN UNTIL THE DOUGLAS COUNTY EROSION CONTROL INSPECTOR APPROVES THE INSTALLATION OF THE INITIAL BMPs AND THE APPROVED DESC PERMIT IS PICKED UP FROM THE COUNTY AND IS IN-HAND ON THE SITE. THE COMPLETED PERMIT WILL BE AVAILABLE WITHIN 24-HOURS AFTER THE INSTALLATION OF THE INITIAL BMPs ARE APPROVED.
12. THE DESC MANAGER SHALL STRICTLY ADHERE TO THE DOUGLAS COUNTY-APPROVED LIMITS OF CONSTRUCTION AT ALL TIMES. THE DOUGLAS COUNTY ENGINEERING DIVISION MUST APPROVE ANY CHANGES TO THE LIMITS OF CONSTRUCTION AND, AT THE DISCRETION OF THE ENGINEERING DIVISION, ADDITIONAL EROSION/SEDIMENT CONTROLS MAY BE REQUIRED IN ANY ADDITIONAL AREAS OF CONSTRUCTION.
13. PRIOR TO ANY CONSTRUCTION ACTIVITIES, THE PERMITTEE SHALL VERIFY THE LOCATION OF EXISTING UTILITIES. FOR INFORMATION, CONTACT THE UTILITY NOTIFICATION CENTER OF COLORADO (UNCC) 1-800-922-1987 OR FAX AT 303-534-6700.
14. NATURAL VEGETATION SHALL BE RETAINED AND PROTECTED WHEREVER POSSIBLE. EXPOSURE OF SOIL TO EROSION BY REMOVAL OR DISTURBANCE OF VEGETATION SHALL BE LIMITED TO THE AREA REQUIRED FOR IMMEDIATE CONSTRUCTION OPERATIONS.
15. THE DESC PERMIT SHALL BE VALID UNTIL THE CERTIFICATE OF OCCUPANCY IS ISSUED.
16. A COPY OF THE DESC PERMIT AND ACCEPTED DESC PLANS SHALL BE ON SITE AT ALL TIMES.
17. THE DESC MANAGER SHALL BE RESPONSIBLE FOR ENSURING THAT THE SITE REMAINS IN COMPLIANCE WITH THE DESC PERMIT AND SHALL BE THE PERMITTEE'S CONTACT PERSON WITH THE COUNTY FOR ALL MATTERS PERTAINING TO THE DESC PERMIT. THE DESC MANAGER SHALL BE PRESENT AT THE SITE THE MAJORITY OF THE TIME AND SHALL BE AVAILABLE THROUGH A 24-HOUR CONTACT NUMBER. IN THE EVENT THAT THE CONTRACTOR'S DESC MANAGER IS NOT ON SITE AND CANNOT BE REACHED DURING A VIOLATION, THE ALTERNATE DESC MANAGER SHALL BE CONTACTED. IF NEITHER THE DESC MANAGER NOR ALTERNATE DESC MANAGER CAN BE CONTACTED DURING ANY VIOLATION, A STOP WORK ORDER SHALL BE ISSUED.
18. ALL CONSTRUCTION TRAFFIC MUST ENTER/EXIT THE SITE THROUGH THE DOUGLAS COUNTY-APPROVED ACCESS POINT. A VEHICLE TRACKING CONTROL PAD OR STABILIZED DRIVEWAY ACCESS IS REQUIRED AT ALL ACCESS POINTS ON THE SITE. ADDITIONAL STABILIZED CONSTRUCTION ENTRANCES MAY BE ADDED WITH AUTHORIZATION FROM THE DOUGLAS COUNTY ENGINEERING DIVISION.
19. THE DESC MANAGER IS RESPONSIBLE FOR CLEANUP OF SEDIMENT OR CONSTRUCTION DEBRIS TRACKED ONTO ADJACENT PAVED AREAS. PAVED AREAS INCLUDING STREETS ARE TO BE KEPT CLEAN THROUGHOUT BUILD-OUT AND SHALL BE CLEANED, WITH A STREET SWEEPER OR SIMILAR DEVICE, AT FIRST NOTICE OF ACCIDENTAL TRACKING OR AT THE DISCRETION OF THE DOUGLAS COUNTY EROSION CONTROL INSPECTOR. STREET WASHING IS NOT ALLOWED. DOUGLAS COUNTY RESERVES THE RIGHT TO REQUIRE ADDITIONAL MEASURES TO ENSURE AREA STREETS ARE KEPT FREE OF SEDIMENT AND/OR CONSTRUCTION DEBRIS.
20. APPROVED EROSION AND SEDIMENT CONTROL BMPs SHALL BE MAINTAINED AND KEPT IN GOOD REPAIR FOR THE DURATION OF THIS PROJECT. AT A MINIMUM, THE DESC MANAGER SHALL INSPECT ALL BMPs IN ACCORDANCE WITH THE ACCEPTED DESC PLAN AND GESC MANUAL. LEVEL III VIOLATIONS SHALL BE CORRECTED IMMEDIATELY AFTER THE PERMITTEE(S) NOTICE THE VIOLATION(S) OR ARE NOTIFIED OF THE VIOLATION(S). GENERALLY DOUGLAS COUNTY WILL REINSPECT FOR COMPLIANCE WITHIN 48 HOURS OF NOTIFICATION OF LEVEL III VIOLATIONS. LEVEL II VIOLATIONS SHALL BE CORRECTED IMMEDIATELY, OR AS DIRECTED BY A DOUGLAS COUNTY EROSION CONTROL INSPECTOR. ACCUMULATED SEDIMENT AND CONSTRUCTION DEBRIS SHALL BE REMOVED AND PROPERLY DISPOSED.
21. STRAW BALES ARE NOT A DOUGLAS COUNTY ACCEPTED SEDIMENT CONTROL BMP.
22. THE ACCEPTED DESC PLAN MAY REQUIRE CHANGES OR ALTERATIONS AFTER APPROVAL TO MEET CHANGING SITE OR PROJECT CONDITIONS OR TO ADDRESS INEFFICIENCIES IN DESIGN OR INSTALLATION. THE DESC MANAGER SHALL OBTAIN PRIOR APPROVAL FROM THE DESIGNER AND DOUGLAS COUNTY ENGINEERING FOR ANY PROPOSED MAJOR CHANGES.
23. NO PERMANENT EARTH SLOPES GREATER THAN 3:1 SHALL BE ALLOWED.
24. ANY SETTLEMENT OR SOIL ACCUMULATIONS BEYOND THE LIMITS OF CONSTRUCTION DUE TO GRADING OR EROSION SHALL BE REPAIRED IMMEDIATELY BY THE DESC MANAGER. THE DESC MANAGER SHALL BE HELD RESPONSIBLE FOR OBTAINING ACCESS RIGHTS TO ADJACENT PROPERTY, IF NEEDED, AND REMEDIATING ANY ADVERSE IMPACTS TO ADJACENT WATERWAYS, WETLANDS, PROPERTIES, ETC. RESULTING FROM WORK DONE AS PART OF THIS PROJECT.
25. ALL CHEMICAL OR HAZARDOUS MATERIAL SPILLS WHICH MAY ENTER WATERS OF THE STATE OF COLORADO, WHICH INCLUDE BUT ARE NOT LIMITED TO, SURFACE WATER, GROUND WATER AND DRY GULLIES OR STORM SEWER LEADING TO SURFACE WATER, SHALL BE IMMEDIATELY REPORTED TO THE CDPHE PER CRS 25-8-601, AND DOUGLAS COUNTY. RELEASES OF PETROLEUM PRODUCTS AND CERTAIN HAZARDOUS SUBSTANCES LISTED UNDER THE FEDERAL CLEAN WATER ACT (40 CFR PART 116) MUST BE REPORTED TO THE NATIONAL RESPONSE CENTER AS WELL AS THE CDPHE. CONTACT INFORMATION FOR CDPHE, DOUGLAS COUNTY AND THE NATIONAL RESPONSE CENTER CAN BE FOUND IN APPENDIX A OF THE GESC MANUAL, AS AMENDED. SPILLS THAT POSE AN IMMEDIATE RISK TO HUMAN LIFE SHALL BE REPORTED TO 911. FAILURE TO REPORT AND CLEAN UP ANY SPILL SHALL RESULT IN ISSUANCE OF A STOP WORK ORDER.
26. ALL WORK ON SITE SHALL STAY A MINIMUM OF ONE HUNDRED (100) FEET AWAY FROM ANY DRAINAGEWAY, WETLAND, ETC. UNLESS OTHERWISE NOTED ON AN ACCEPTED DOUGLAS COUNTY DESC PLAN.
27. THE USE OF REBAR, STEEL STAKES OR STEEL FENCE POSTS FOR STAKING OR SUPPORT OF ANY EROSION OR SEDIMENT CONTROL BMP IS PROHIBITED (EXCEPT STEEL TEE-POSTS FOR USE IN SUPPORTING CONSTRUCTION FENCE).
28. THE CLEANING OF CONCRETE DELIVERY TRUCK CHUTES IS RESTRICTED TO APPROVED CONCRETE WASH OUT LOCATIONS ON THE JOB SITE. THE DISCHARGE OF WATER CONTAINING WASTE CONCRETE TO THE STORM SEWER SYSTEM IS PROHIBITED. ALL CONCRETE WASTE SHALL BE PROPERLY CLEANED UP AND DISPOSED AT AN APPROPRIATE LOCATION.
29. ALL DEWATERING ON SITE SHALL BE COORDINATED WITH A DOUGLAS COUNTY EROSION CONTROL INSPECTOR AND BE FREE OF SEDIMENT IN ACCORDANCE WITH THE GESC MANUAL.
30. ALL PERMANENT INSTALLATIONS OF PIPES FOR STORM SEWERS, SLOPE DRAINS, AND CULVERTS, TOGETHER WITH RIPRAP APRONS OR OTHER INLET AND OUTLET PROTECTION, REQUIRE INSPECTION BY DOUGLAS COUNTY ENGINEERING (SEPARATE FROM GESC INSPECTIONS).
31. HYDRAULIC SEEDING AND HYDRAULIC MULCHING ARE NOT AN ACCEPTABLE METHOD OF SEEDING OR MULCHING IN DOUGLAS COUNTY.
32. A FINAL DESC INSPECTION SHALL BE CONDUCTED FOR CERTIFICATE OR TEMPORARY CERTIFICATE OF OCCUPANCY.

DETAIL SHEET NO. NO.

- | | |
|----|---|
| 1 | 2 |
| 2 | 2 |
| 3 | 2 |
| 4 | 3 |
| 5 | 3 |
| 6 | 4 |
| 7 | 5 |
| 8 | 6 |
| 9 | 6 |
| 10 | 6 |
| 11 | 7 |
| 12 | 8 |
| 13 | 8 |
| 14 | 8 |
| 15 | 9 |
| | 9 |

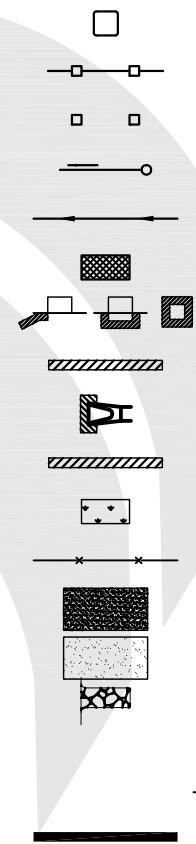

BMP LEGEND

- | | | |
|-------|------------|----------------------------|
| | CWA | CONCRETE WASHOUT AREA |
| | CF | CONSTRUCTION FENCE |
| | CM | CONSTRUCTION MARKERS |
| | DW | DEWATERING |
| | DD | DIVERSION DITCH |
| | ECB | EROSION CONTROL BLANKET |
| | IP | INLET PROTECTION |
| | RRB | REINFORCED ROCK BERM |
| | RRC | RRB FOR CULVERT PROTECTION |
| | SCL | SEDIMENT CONTROL LOG |
| | SM | SEEDING AND MULCHING |
| | SF | SILT FENCE |
| | SDA | STABILIZED DRIVEWAY ACCESS |
| | SSA | STABILIZED STAGING AREA |
| | VTC | VEHICLE TRACKING CONTROL |
| ----- | | |
| | LOC | LIMITS OF CONSTRUCTION |

C:\Land Projects\2009\GESC_Manual.dwg\DESC Details 1-9.dwg, 1/10/2013 4:42:27 PM, 1:2

Sheet Revisions	

NOTE: SCALES SHOWN ARE FOR 22"x34" SHEETS; ADJUST ACCORDINGLY FOR 11"x17" SHEETS.

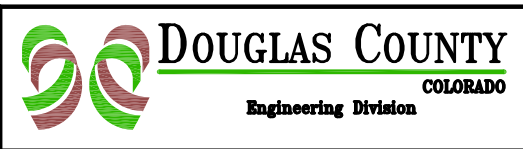

DESC DRAINAGE, EROSION, AND SEDIMENT CONTROL

DESC PLAN STANDARD NOTES AND DETAILS

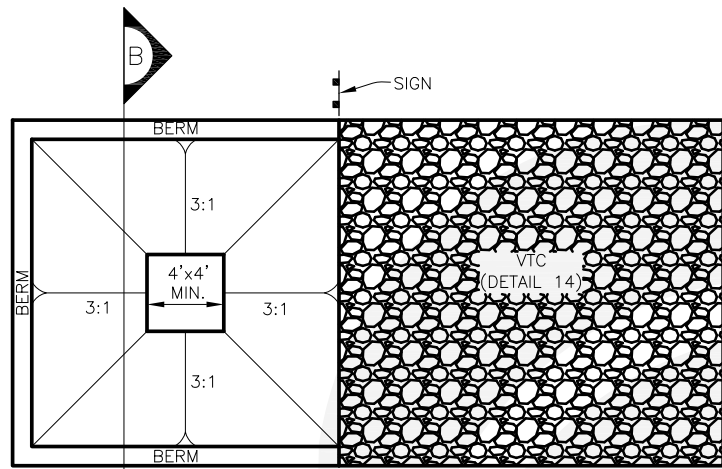

PLAN

SCALE: 1" = 5'-0"

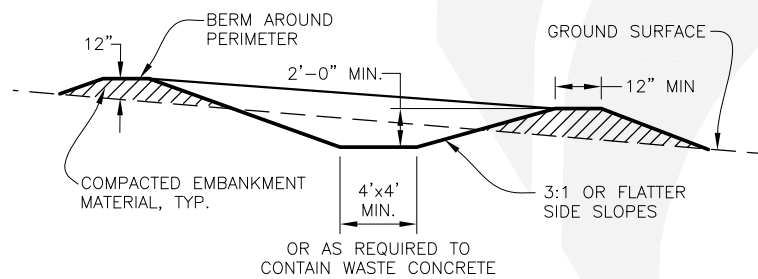

SECTION B

SCALE: 1" = 5'-0"

CONCRETE WASHOUT AREA INSTALLATION NOTES

1. SEE PLAN VIEW FOR:
- LOCATIONS OF CONCRETE WASHOUT AREA.
2. THE CONCRETE WASHOUT AREA SHALL BE INSTALLED PRIOR TO ANY CONCRETE PLACEMENT ON SITE.
3. VEHICLE TRACKING CONTROL (DETAIL 15) IS REQUIRED AT THE ACCESS POINT.
4. SIGNS SHALL BE PLACED AT THE CONSTRUCTION ENTRANCE, AT THE WASHOUT AREA, AND ELSEWHERE AS NECESSARY TO CLEARLY INDICATE THE LOCATION OF THE CONCRETE WASHOUT AREA TO OPERATORS OF CONCRETE TRUCKS AND PUMP RIGS.
5. EXCAVATED MATERIAL SHALL BE UTILIZED IN PERIMETER BERM CONSTRUCTION.
6. DURABLE PORTABLE CONCRETE WASHOUT BASINS OR TUBS MAY BE USED WITH THE APPROVAL OF THE EROSION CONTROL INSPECTOR.

CONCRETE WASHOUT AREA MAINTENANCE NOTES

1. THE CONCRETE WASHOUT AREA SHALL BE REPAIRED AND ENLARGED OR CLEANED OUT AS NECESSARY TO MAINTAIN CAPACITY FOR WASTED CONCRETE.
2. AT THE END OF CONSTRUCTION, ALL CONCRETE SHALL BE REMOVED FROM THE SITE AND DISPOSED OF AT AN APPROVED WASTE SITE.
3. WHEN THE CONCRETE WASHOUT AREA IS REMOVED, THE DISTURBED AREA SHALL BE DRILL SEEDED AND CRIMP MULCHED OR OTHERWISE STABILIZED IN A MANNER APPROVED BY THE COUNTY.
4. INSPECT WEEKLY, DURING AND AFTER ANY STORM EVENT.

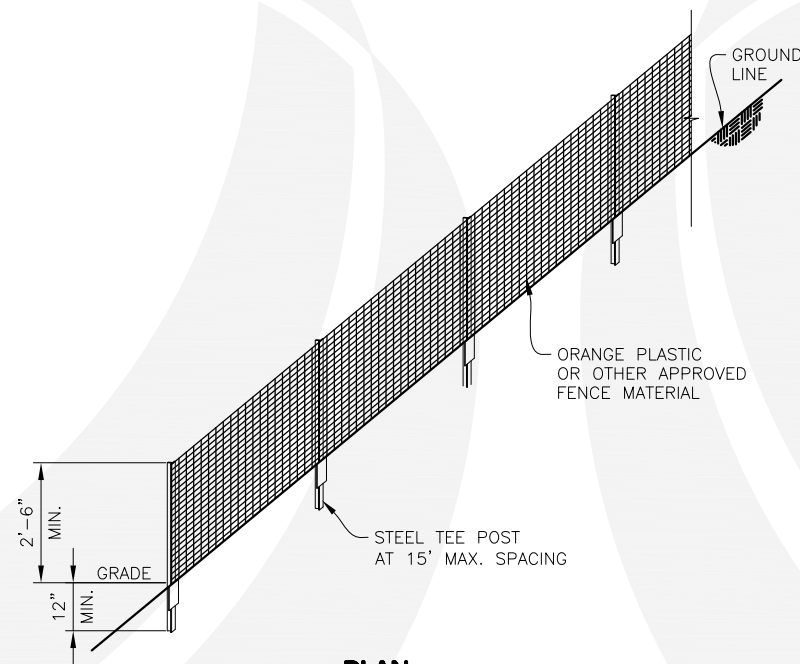

PLAN

SCALE: 1/2" = 1'-0"

CONSTRUCTION FENCE INSTALLATION NOTES

1. SEE PLAN VIEW FOR:
- TYPE OF CONSTRUCTION LIMIT INDICATOR (FENCE OR MARKERS).
- LOCATION AND LENGTH OF FENCE OR LINE OF MARKERS.
2. CONSTRUCTION FENCE OR MARKERS INDICATED ON INITIAL GESC PLAN SHALL BE INSTALLED PRIOR TO OTHER BMPs AND ANY LAND-DISTURBING ACTIVITIES.
3. STEEL TEE POSTS SHALL BE UTILIZED FOR SUPPORT OF CONSTRUCTION FENCE. MAXIMUM SPACING FOR TEE POSTS SHALL BE 15'.

CONSTRUCTION FENCE MAINTENANCE NOTES

1. ANY DAMAGED FENCE OR MARKERS SHALL BE REPAIRED ON A DAILY BASIS.
2. FENCE OR MARKERS SHALL BE REMOVED AT THE END OF CONSTRUCTION. IF ANY DISTURBED AREA EXISTS AFTER FENCE REMOVAL, IT SHALL BE DRILL SEEDED AND CRIMP MULCHED OR OTHERWISE STABILIZED IN A MANNER APPROVED BY THE COUNTY.

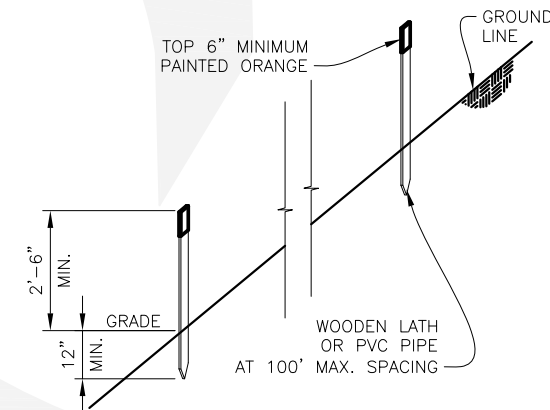

(ALTERNATIVE TO CONSTRUCTION FENCE)
SCALE: 1/2" = 1'-0"



CWA CONCRETE WASHOUT AREA

1

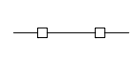

CF CONSTRUCTION FENCE

2



CM CONSTRUCTION MARKERS

3

Sheet Revisions	

NOTE: SCALES SHOWN ARE FOR 22"x34" SHEETS; ADJUST ACCORDINGLY FOR 11"x17" SHEETS.

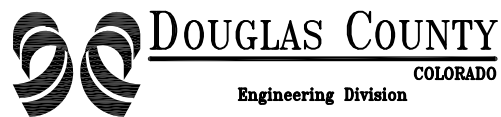

DESC DRAINAGE, EROSION, AND SEDIMENT CONTROL

DESC PLAN STANDARD NOTES AND DETAILS

SHEET 2 OF 9

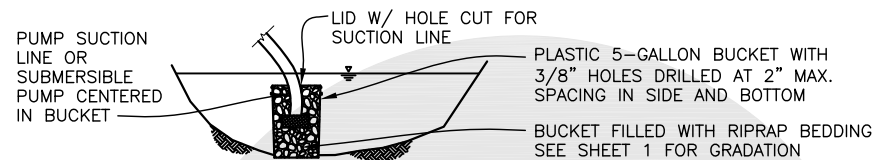

**ALTERNATIVE FOR DRAINING POND
ALREADY FILLED WITH WATER**

SCALE: 1/2" = 1'-0"

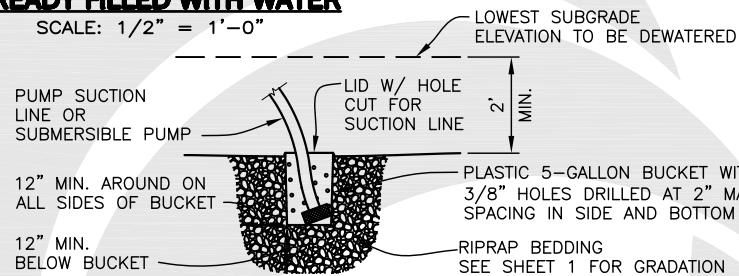

DEWATERING SUMP FOR SUBMERSIBLE PUMP

SCALE: 1/2" = 1'-0"

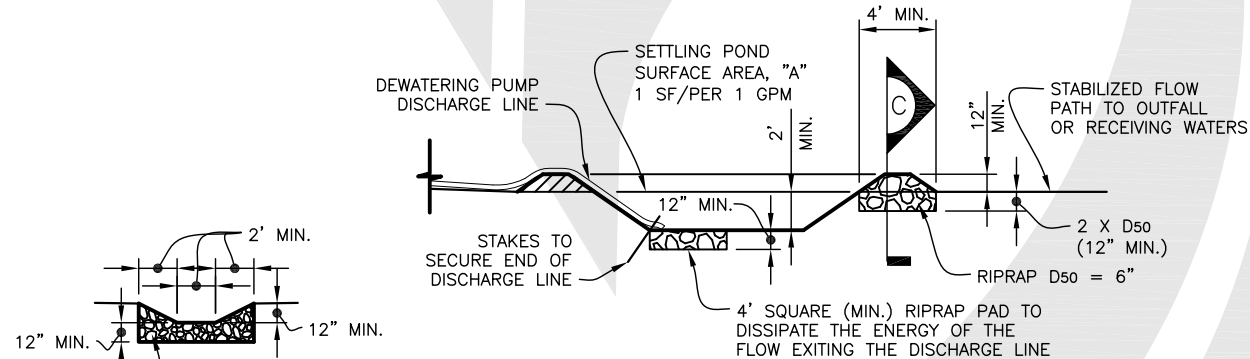

**SUMP DISCHARGE
SETTLING BASIN**

SCALE: 1" = 5'-0"

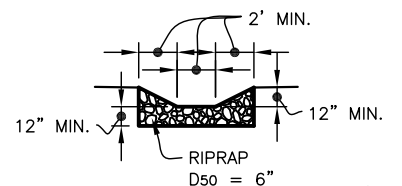

BASIN OUTLET - SECTION C

SCALE: 1" = 5'-0"

DEWATERING INSTALLATION NOTES

1. THE PERMITEE(S) SHALL SCHEDULE AN ONSITE INSPECTION WITH THE EROSION CONTROL INSPECTOR PRIOR TO ANY SITE DEWATERING OPERATIONS BEGIN.
2. THE GESC MANAGER SHALL OBTAIN A CONSTRUCTION DEWATERING PERMIT (DEWATERING PERMIT) FROM THE COLORADO DEPARTMENT OF PUBLIC HEALTH AND ENVIRONMENT (CDPHE) PRIOR TO ANY DEWATERING OPERATIONS THAT REQUIRE A DEWATERING PERMIT.
3. AT A MINIMUM, THE DEWATERING BMPs SHALL CONSIST OF THE FOLLOWING: PRE-FILTER ON THE SUCTION END OF THE PUMP/HOSE, FILTER BMP PRIOR TO FINAL DISCHARGE, AND ENERGY DISSIPATING BMP AT THE DISCHARGE END OF THE HOSE/PUMP.
4. THE TYPE AND PLACEMENT OF DEWATERING CONTROLS SHALL BE COORDINATED WITH, AND APPROVED BY, THE EROSION CONTROL INSPECTOR PRIOR TO THE DISCHARGE OF ANY WATER.

DEWATERING MAINTENANCE NOTES

1. THE DESC MANAGER SHALL INSPECT DEWATERING SYSTEMS AND PERFORM ANY NECESSARY REPAIRS OR MAINTENANCE ON A HOURLY BASIS.
2. TEMPORARY SETTLING BASINS SHALL BE REMOVED WHEN NO LONGER NEEDED FOR DEWATERING OPERATIONS. ANY DISTURBED AREA SHALL BE DRILL SEEDED AND CRIMP MULCHED OR OTHERWISE STABILIZED IN A MANNER APPROVED BY THE COUNTY.

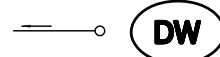

DEWATERING

4

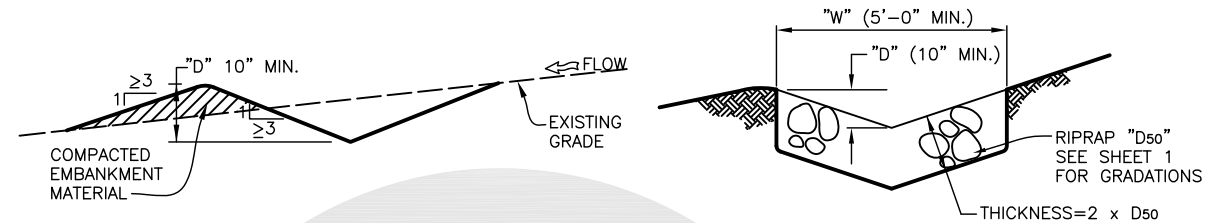

UNLINED

LONGITUDINAL SLOPE $\leq 0.5\%$
SCALE: 1/2" = 1'-0"

RIPRAP LINED

LONGITUDINAL SLOPE 3% TO 33%
SCALE: 1/2" = 1'-0"

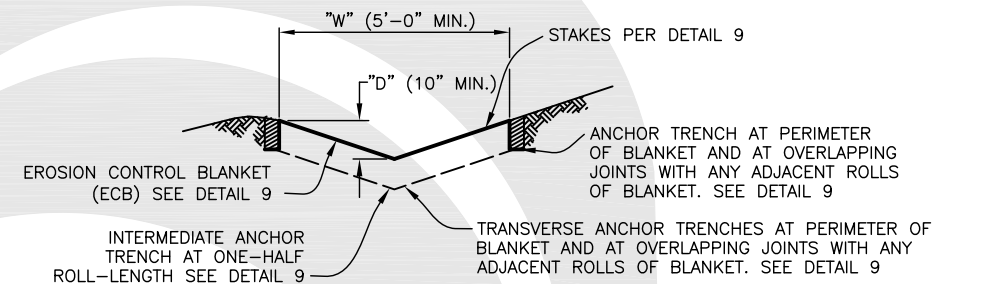

EROSION CONTROL BLANKET (ECB) LINED

LONGITUDINAL SLOPE 0.5% TO 3%
SCALE: 1/2" = 1'-0"

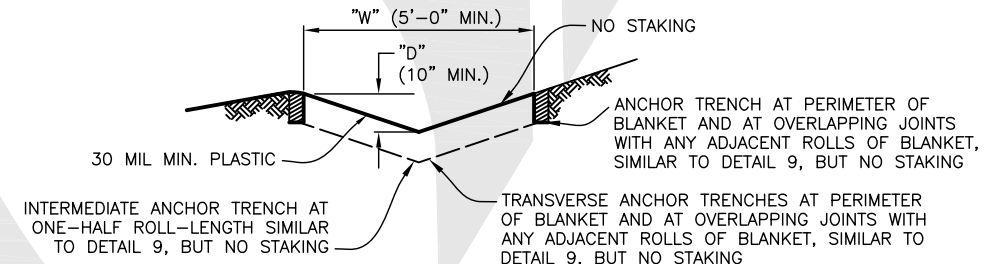

PLASTIC LINED

LONGITUDINAL SLOPE 3% TO 33%
SCALE: 1/2" = 1'-0"

DIVERSION DITCH INSTALLATION NOTES

1. SEE PLAN VIEW FOR:
 - LOCATION OF DIVERSION DITCH.
 - TYPE OF DITCH (UNLINED, ECB LINED, PLASTIC LINED OR RIPRAP LINED).
 - LENGTH OF EACH TYPE OF DITCH.
 - DEPTH, "D", AND WIDTH, "W" DIMENSIONS.
 - FOR ECB LINED DITCH, EROSION CONTROL BLANKET TYPE (SEE DETAIL 6).
 - FOR RIPRAP LINED DITCH, SIZE OF RIPRAP, "D50".
2. SEE DRAINAGE PLANS FOR DETAILS OF ANY PERMANENT CONVEYANCE FACILITIES OR DIVERSION DITCHES EXCEEDING A 2-YEAR FLOW RATE OF 10 CFS.
3. DIVERSION DITCHES INDICATED ON INITIAL GESC PLAN SHALL BE INSTALLED PRIOR TO ANY LAND-DISTURBING ACTIVITIES.
4. FOR ECB LINED DITCHES, INSTALLATION OF EROSION CONTROL BLANKET SHALL CONFORM TO THE REQUIREMENTS OF DETAIL 9.
5. IN LOCATIONS WHERE CONSTRUCTION TRAFFIC MUST CROSS A DIVERSION DITCH, THE PERMITEES SHALL INSTALL A TEMPORARY CULVERT WITH A MINIMUM DIAMETER OF 12-INCHES.

DIVERSION DITCH MAINTENANCE NOTES

1. THE GESC MANAGER SHALL INSPECT DIVERSION DITCHES WEEKLY, DURING AND AFTER ANY STORM EVENT AND MAKE REPAIRS OR CLEAN OUT AS NECESSARY.
2. DIVERSION DITCHES ARE TO REMAIN IN PLACE UNTIL THE END OF CONSTRUCTION, OR, IF APPROVED BY THE COUNTY, LEFT IN PLACE.
3. IF DIVERSION DITCHES ARE REMOVED, THE DISTURBED AREA SHALL BE DRILL SEEDED AND CRIMP MULCHED OR OTHERWISE STABILIZED IN A MANNER APPROVED BY THE COUNTY.

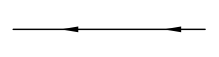

DIVERSION DITCH

5

Sheet Revisions	

NOTE: SCALES SHOWN ARE FOR 22"x34" SHEETS; ADJUST ACCORDINGLY FOR 11"x17" SHEETS.

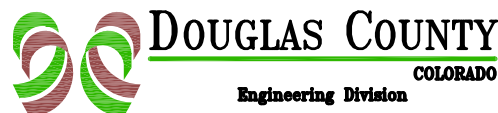

DESC DRAINAGE, EROSION, AND SEDIMENT CONTROL

DESC PLAN STANDARD NOTES AND DETAILS

SHEET 3 OF 9

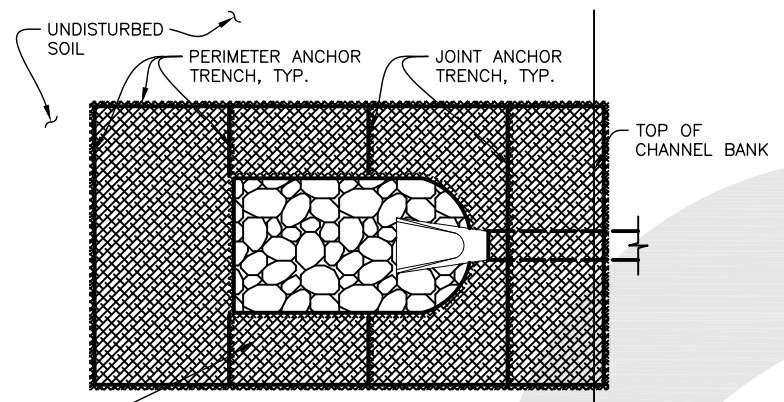

TYPE OF BLANKET AS INDICATED IN PLAN VIEW, IN ALL DISTURBED AREAS OF STREAMS AND DRAINAGE CHANNELS TO DEPTH "D" ABOVE CHANNEL INVERT. BLANKET SHALL GENERALLY BE ORIENTED PARALLEL TO FLOW DIRECTION. STAKING PATTERN SHALL MATCH BLANKET TYPE.

IN DISTURBED AREAS OF STREAMS AND DRAINAGE CHANNELS
SCALE: 1" = 5'-0"

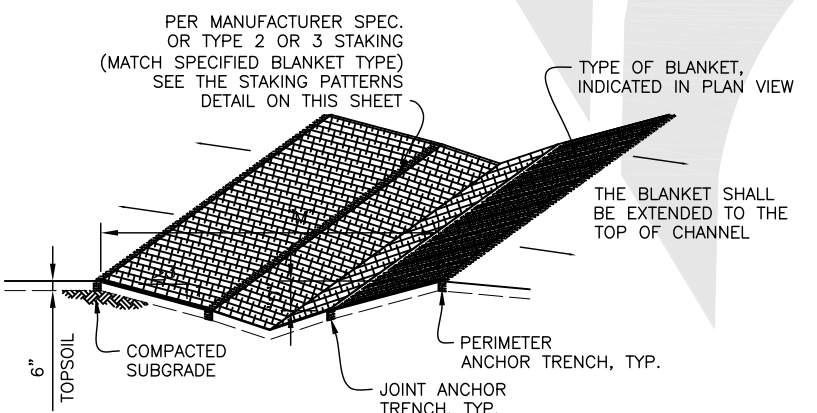

IN DIVERSION DITCH OR SMALL DITCH DRAINAGEWAY
SCALE: 1" = 5'-0"

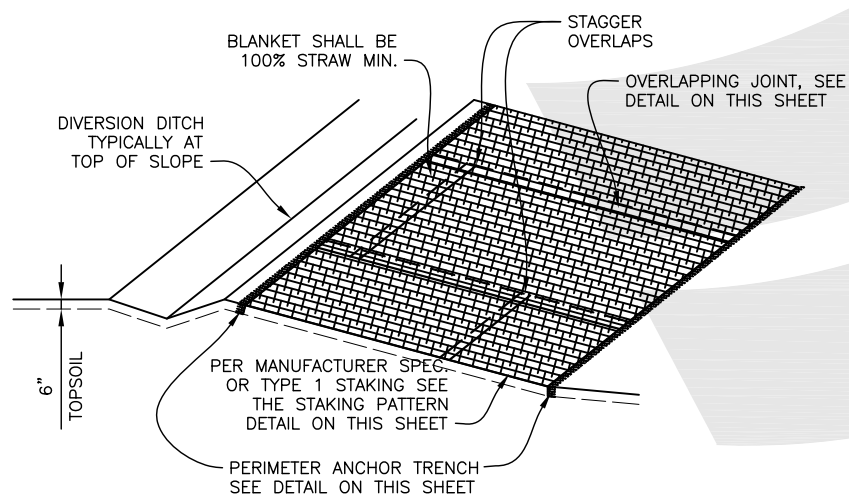

OUTSIDE OF STREAMS AND DRAINAGE CHANNELS
SCALE: 1" = 5'-0"

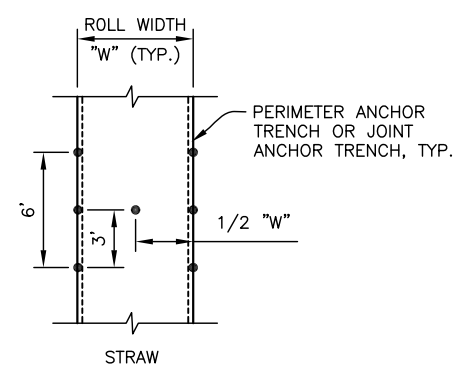

STRAW

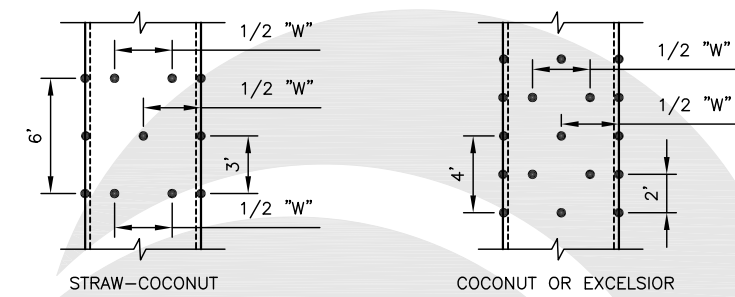

STRAW-COCONUT

COCONUT OR EXCELSIOR

STAKING PATTERNS

SCALE: 1" = 5'-0"
SHALL BE IN ACCORDANCE WITH MANUFACTURER'S SPECIFICATION. IF NO MANUFACTURER'S SPECIFICATION IS AVAILABLE USE THE ACCEPTABLE STAKING PATTERN (AS SHOWN ABOVE).

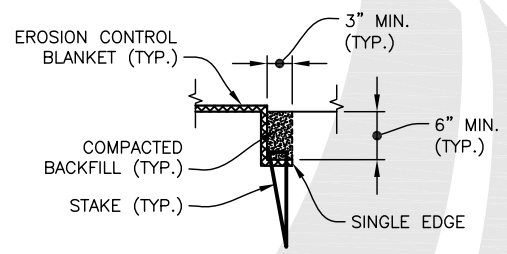

PERIMETER ANCHOR TRENCH
SCALE: 1" = 1'-0"

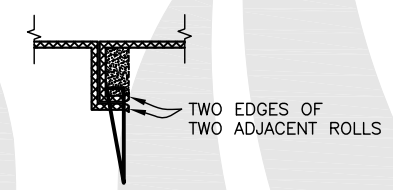

JOINT ANCHOR TRENCH
SCALE: 1" = 1'-0"

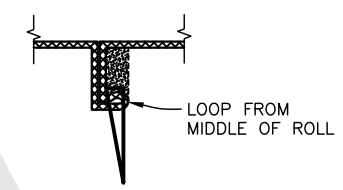

INTERMEDIATE ANCHOR TRENCH
SCALE: 1" = 5'-0"

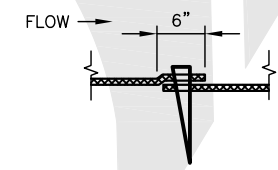

OVERLAPPING JOINT
SCALE: 1" = 1'-0"

EROSION CONTROL BLANKET INSTALLATION NOTES

- SEE PLAN VIEW FOR:
- LOCATION OF PERIMETER OF EROSION CONTROL BLANKET.
- TYPE OF BLANKET (STRAW, STRAW-COCONUT, COCONUT, OR EXCELSIOR).
- AREA "A" IN SQUARE YARDS OF EACH TYPE OF BLANKET.
- FOR DESC PERMITTED PROJECTS EROSION CONTROL BLANKETS MADE FROM PHOTO-DEGRADABLE MATERIAL MAY BE USED IN AREAS THAT WILL RECEIVE PERMANENT LANDSCAPING. EROSION CONTROL BLANKETS THAT ARE USED FOR TEMPORARY STABILIZATION PRIOR TO LANDSCAPING SHALL NOT REQUIRE SEEDING UNDERNEATH THE BLANKETS.
- IN AREAS WHERE EROSION CONTROL BLANKET IS SHOWN ON THE PLANS, THE PERMITTEE SHALL PERFORM FINAL GRADING AND SURFACE PREPARATION BELOW THE BLANKET IN ACCORDANCE WITH THE PLAN. SUBGRADE SHALL BE SMOOTH AND MOIST PRIOR TO BLANKET INSTALLATION AND THE BLANKET SHALL BE IN FULL CONTACT WITH SUBGRADE, NO GAPS OR VOIDS SHALL EXIST UNDER THE BLANKET. STRAW MULCH SHALL NOT BE REQUIRED IN AREAS THAT ARE COVERED WITH EROSION CONTROL BLANKETS. EROSION CONTROL BLANKETS THAT ARE USED FOR TEMPORARY STABILIZATION, PRIOR TO LANDSCAPING, SHALL NOT REQUIRE SEEDING UNDERNEATH THE BLANKETS.
- PERIMETER ANCHOR TRENCH SHALL BE USED AT OUTSIDE PERIMETER OF ALL BLANKET AREAS.
- JOINT ANCHOR TRENCH SHALL BE USED TO JOIN ROLLS OF BLANKETS TOGETHER (LONGITUDINALLY AND TRANSVERSELY) FOR ALL BLANKETS INSTALLATIONS IN A DRAINAGEWAY EXCEPT STRAW, WHICH MAY USE AN OVERLAPPING JOINT.
- INTERMEDIATE ANCHOR TRENCH SHALL BE USED AT SPACING OF ONE-HALF THE ROLL LENGTH FOR COCONUT AND EXCELSIOR BLANKETS.
- THE OVERLAPPING JOINT DETAIL SHALL BE USED TO JOIN ROLLS OF BLANKETS TOGETHER FOR BLANKETS ON SLOPES.
- MATERIAL SPECIFICATIONS OF EROSION CONTROL BLANKET SHALL CONFORM TO TABLE 7.1.

EROSION CONTROL BLANKET INSTALLATION NOTES - CONTINUED

- ANY AREAS OF SEEDING AND MULCHING DISTURBED IN THE PROCESS OF INSTALLING EROSION CONTROL BLANKET SHALL BE RESEED AND MULCHED IN ACCORDANCE WITH DETAIL 11.
- SEE DRAINAGE DESIGN PLANS FOR MAJOR DRAINAGEWAY STABILIZATION MEASURES THAT MAY EXCEED THE DESIGN CONDITIONS ASSOCIATED WITH THE DETAILS ABOVE.
- METAL STAKES OR STAPLES MAY BE USED FOR EROSION CONTROL BLANKET INSTALLATIONS OUTSIDE OF DRAINAGE CHANNELS.

TYPE	COCONUT CONTENT	STRAW CONTENT	EXCELSIOR CONTENT	NETTING MIN.
STRAW*	-	100%	-	DOUBLE/NATURAL
STRAW-COCONUT	30% MIN.	70% MAX.	-	DOUBLE/NATURAL
COCONUT	100%	-	-	DOUBLE/NATURAL
EXCELSIOR	-	-	100%	DOUBLE/NATURAL
PHOTODEGRADABLE STRAW*	-	100%	-	DOUBLE/NATURAL
PHOTODEGRADABLE STRAW-COCONUT	30% MIN.	70% MAX.	-	DOUBLE/NATURAL
PHOTODEGRADABLE COCONUT	100%	-	-	DOUBLE/NATURAL
PHOTODEGRADABLE EXCELSIOR	-	-	100%	DOUBLE/NATURAL

* FOR OUTSIDE OF STREAMS AND DRAINAGE CHANNELS

EROSION CONTROL BLANKET MAINTENANCE NOTES

- THE DESC MANAGER SHALL INSPECT EROSION CONTROL BLANKETS WEEKLY, DURING AND AFTER ANY STORM EVENT AND MAKE REPAIRS AS NECESSARY.
- EROSION CONTROL BLANKET IS TO BE LEFT IN PLACE UNLESS REQUESTED TO BE REMOVED BY THE COUNTY.
- ANY EROSION CONTROL BLANKET PULLED OUT, TORN, OR OTHERWISE DAMAGED SHALL BE RE-INSTALLED. ANY SUBGRADE AREAS BELOW THE BLANKET THAT HAVE ERODED TO CREATE A VOID UNDER THE BLANKET, OR THAT REMAIN DEVOID OF GRASS SHALL BE REPAIRED, RESEED AND THE EROSION CONTROL BLANKET REINSTALLED.



ECB EROSION CONTROL BLANKET **6**

C:\Land Projects 2009\GESC_Manual.dwg\DESC Details 1-9.dwg, 1/10/2013 10:50:19 AM, 1:2

Sheet Revisions	

NOTE: SCALES SHOWN ARE FOR 22"x34" SHEETS; ADJUST ACCORDINGLY FOR 11"x17" SHEETS.

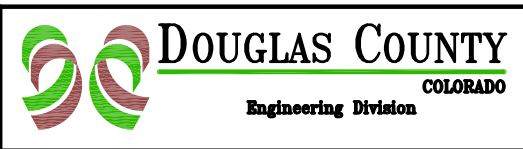

DESC DRAINAGE, EROSION, AND SEDIMENT CONTROL

DESC PLAN STANDARD NOTES AND DETAILS

SHEET 4 OF 9

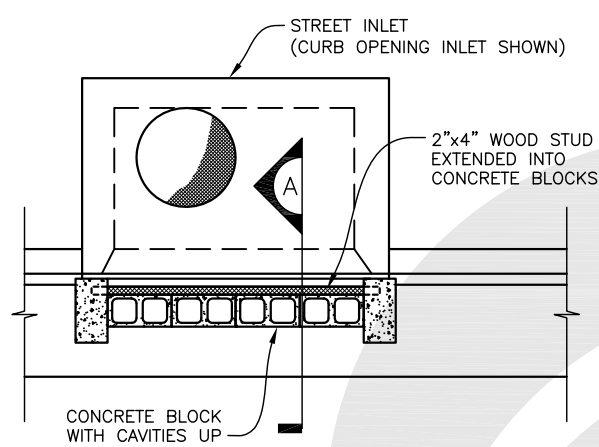

INTERIM CONFIGURATION (BEFORE PAVING) STREET INLET - PLAN
SCALE: 1/2" = 1'-0"

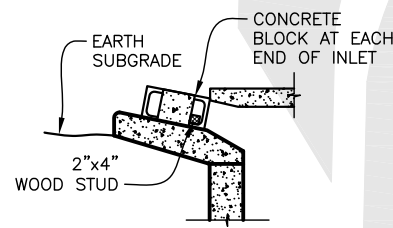

SECTION A
SCALE: 1/2" = 1'-0"

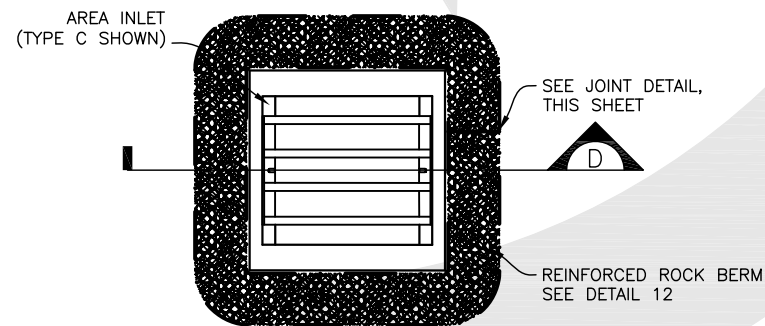

AREA INLET - PLAN
SCALE: 1/2" = 1'-0"

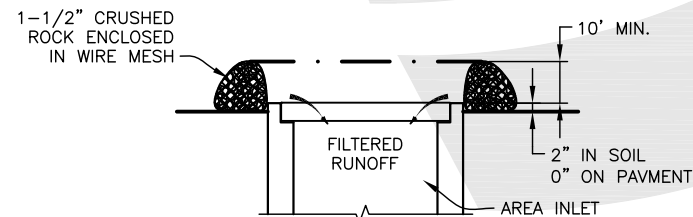

SECTION D
SCALE: 1/2" = 1'-0"

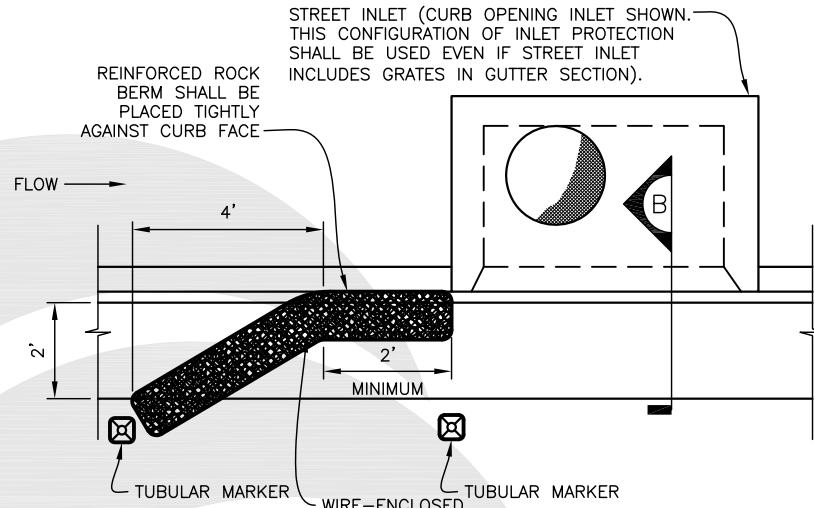

STREET INLET ON CONTINUOUS GRADE (AFTER PAVING) - PLAN
SCALE: 1/2" = 1'-0"

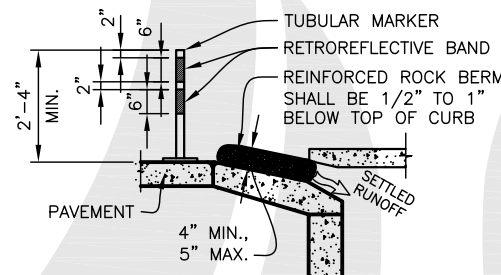

SECTION B
SCALE: 1/2" = 1'-0"

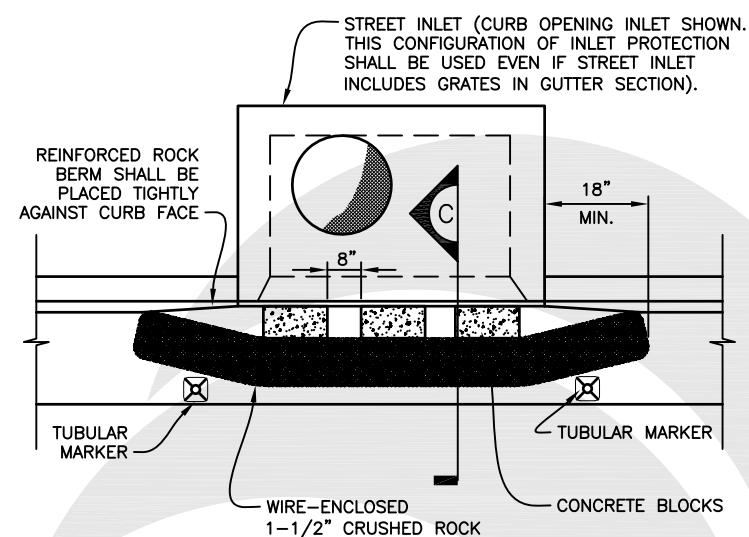

STREET INLET IN SUMP (AFTER PAVING) - PLAN
SCALE: 1/2" = 1'-0"

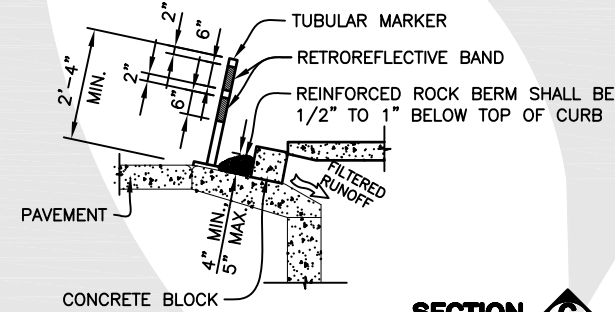

SECTION C
SCALE: 1/2" = 1'-0"

ANY GAP AT JOINT SHALL BE FILLED WITH 1 1/2" CRUSHED ROCK AND WRAPPED WITH ADDITIONAL WIRE MESH SECURED TO ENDS OF ROCK REINFORCED BERM

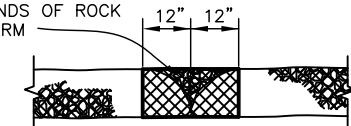

JOINT DETAIL
SCALE: 1/2" = 1'-0"

INLET PROTECTION INSTALLATION NOTES

1. INTERIM CONFIGURATION OF INLET PROTECTION IN STREETS SHALL BE INSTALLED WITHIN 48-HOURS OF POURING INLET. INLET PROTECTION (AFTER PAVEMENT) SHALL BE INSTALLED WITHIN 48 HOURS AFTER PAVING IS PLACED.
2. INLET PROTECTION AT AREA INLETS SHALL BE INSTALLED WITHIN 48-HOURS OF POURING INLET.
3. CRUSHED ROCK SHALL BE FRACTURED FACE (ALL SIDES) AND SHALL COMPLY WITH GRADATION SHOWN ON SHEET 9 (1-1/2"). RECYCLED CONCRETE MEETING THIS GRADATION MAY BE USED.
4. WIRE MESH SHALL BE FABRICATED OF 20 GAUGE WIRE TWISTED INTO A MESH WITH A MAXIMUM OPENING OF 1.0 INCH (COMMONLY TERMED "CHICKEN WIRE"). ROLL WIDTH SHALL BE 48-INCHES.
5. WIRE MESH SHALL BE SECURED USING "HOG RINGS" OR WIRE TIES AT 6-INCH CENTERS ALONG ALL JOINTS AND AT 2-INCH CENTERS ON ENDS OF BERM.
6. REINFORCED ROCK BERM SHALL BE CONSTRUCTED IN ONE PIECE OR SHALL BE CONSTRUCTED USING JOINT DETAIL.
7. TUBULAR MARKERS SHALL MEET REQUIREMENTS OF MANUAL ON UNIFORM TRAFFIC CONTROL DEVICES (MUTCD), AS AMENDED.
8. THE TOP OF REINFORCED ROCK BERM SHALL BE 1/2"-1" BELOW TOP OF CURB.

INLET PROTECTION MAINTENANCE NOTES

1. THE DESC MANAGER SHALL INSPECT INLET PROTECTION WEEKLY, DURING AND AFTER ANY STORM EVENT AND MAKE REPAIRS OR CLEAN OUT AS NECESSARY. MORE FREQUENT INSPECTIONS AND REPAIRS SHALL BE REQUIRED DURING WINTER CONDITIONS DUE TO FREEZE/THAW PROBLEMS.
2. SEDIMENT ACCUMULATED UPSTREAM OF INLET PROTECTION SHALL BE REMOVED WHEN THE SEDIMENT DEPTH UPSTREAM OF ROCK BERM IS WITHIN 2-1/2 INCHES OF THE CREST.
3. INLET PROTECTION IS TO REMAIN IN PLACE UNTIL THE UPSTREAM DISTURBED AREA IS STABILIZED AND GRASS COVER IS APPROVED, UNLESS THE COUNTY APPROVES EARLIER REMOVAL OF INLET PROTECTION IN STREETS.
4. WHEN INLET PROTECTION AT AREA INLETS ARE REMOVED, THE DISTURBED AREA SHALL BE DRILL SEEDED AND CRIMP MULCHED OR OTHERWISE STABILIZED IN A MANNER APPROVED BY THE COUNTY.

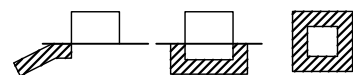

IP INLET PROTECTION 7

Sheet Revisions	

NOTE: SCALES SHOWN ARE FOR 22"x34" SHEETS; ADJUST ACCORDINGLY FOR 11"x17" SHEETS.

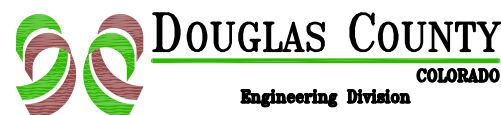

DESC DRAINAGE, EROSION, AND SEDIMENT CONTROL

DESC PLAN STANDARD NOTES AND DETAILS

SHEET 5 OF 9

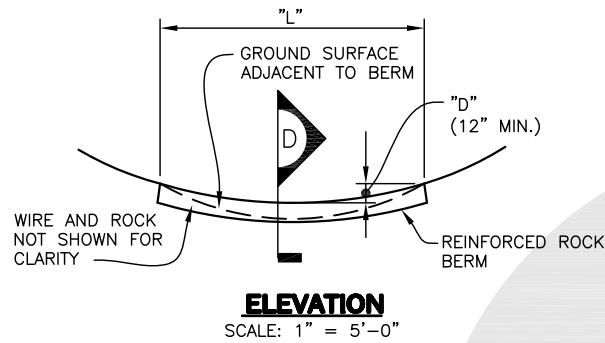

ELEVATION
SCALE: 1" = 5'-0"

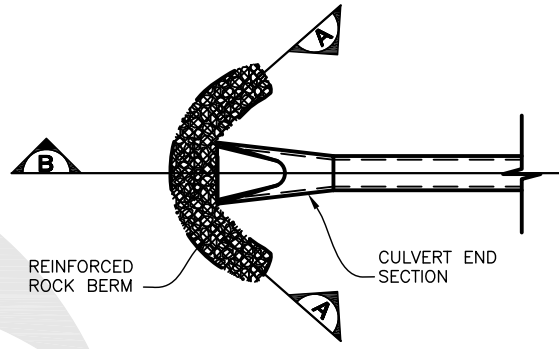

PLAN
SCALE: 1" = 5'-0"

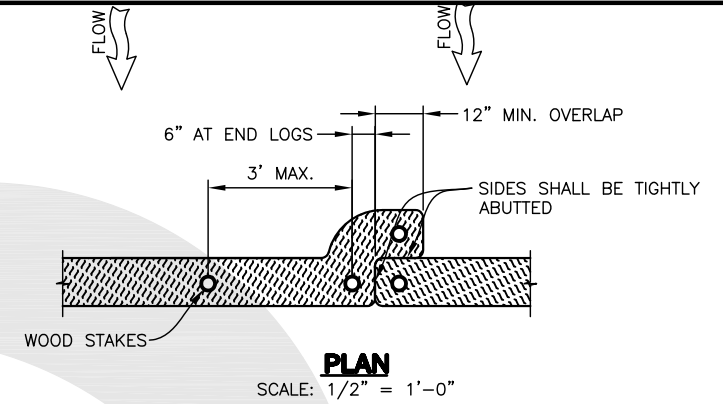

PLAN
SCALE: 1/2" = 1'-0"

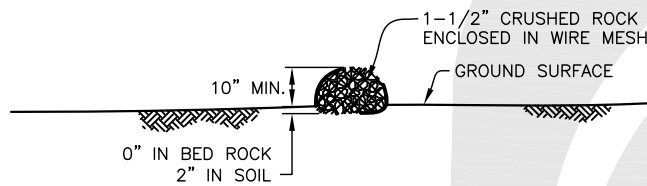

SECTION D
SCALE: 1/2" = 1'-0"

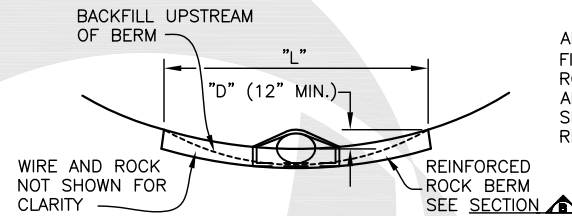

SECTION A
SCALE: 1" = 5'-0"

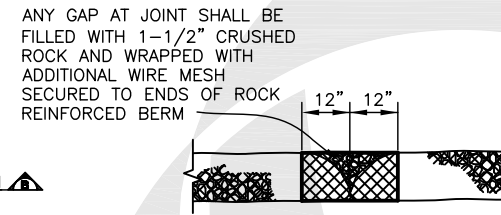

JOINT DETAIL
SCALE: 1/2" = 1'-0"

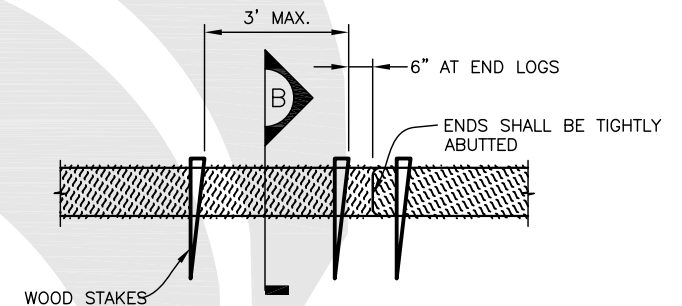

ELEVATION
SCALE: 1/2" = 1'-0"

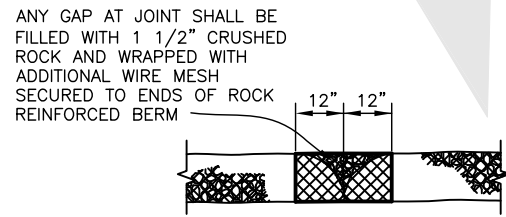

JOINT DETAIL
SCALE: 1/2" = 1'-0"

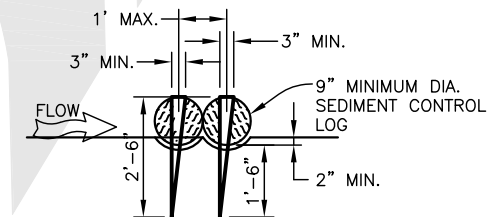

SECTION B
SCALE: 1/2" = 1'-0"

REINFORCED ROCK BERM INSTALLATION NOTES

- SEE PLAN VIEW FOR:
 - LOCATIONS OF REINFORCED ROCK BERMS.
 - LENGTH, "L", AND DEPTH, "D" DIMENSIONS.
- REINFORCED ROCK BERM SECTION APPLIES TO CULVERT INLET FILTER AND INLET PROTECTION.
- CRUSHED ROCK SHALL BE FRACTURED FACE (ALL SIDES) AND SHALL COMPLY WITH GRADATION SHOWN ON SHEET 9 (1-1/2"). RECYCLED CONCRETE MEETING THIS GRADATION MAY BE USED.
- WIRE MESH SHALL BE FABRICATED OF 20 GAUGE WIRE TWISTED INTO A MESH WITH A MAXIMUM OPENING OF 1.0 INCH (COMMONLY TERMED "CHICKEN WIRE"). ROLL WIDTH SHALL BE 48-INCHES.
- WIRE MESH SHALL BE SECURED USING "HOG RINGS" OR WIRE TIES AT 6-INCH CENTERS ALONG ALL JOINTS AND AT 2-INCH CENTERS ON ENDS OF BERM.
- FOR CONCENTRATED FLOW AREAS THE ENDS OF THE REINFORCED ROCK BERM SHALL BE 12" HIGHER THAN THE CENTER OF THE BERM.

REINFORCED ROCK BERM MAINTENANCE NOTES

- THE DESC MANAGER SHALL INSPECT REINFORCED ROCK BERM WEEKLY, DURING AND AFTER ANY STORM EVENT AND MAKE REPAIRS OR CLEAN OUT AS NECESSARY.
- SEDIMENT ACCUMULATED UPSTREAM OF REINFORCED ROCK BERM SHALL BE REMOVED WHEN THE SEDIMENT DEPTH UPSTREAM OF FILTER IS WITHIN 5 INCHES OF THE CREST.
- REINFORCED ROCK BERMS ARE TO REMAIN IN PLACE UNTIL THE UPSTREAM DISTURBED AREA IS STABILIZED AND GRASS COVER IS APPROVED.
- WHEN REINFORCED ROCK BERMS ARE REMOVED, ANY DISTURBED AREA SHALL BE DRILL SEEDED AND CRIMP MULCHED OR OTHERWISE STABILIZED IN A MANNER APPROVED BY THE COUNTY.

INSTALLATION NOTES

- SEE PLAN VIEW FOR:
 - LOCATIONS OF CULVERT INLET FILTERS.
 - LENGTH, "L", AND DEPTH, "D".
- CRUSHED ROCK SHALL BE FRACTURED FACE (ALL SIDES) AND SHALL COMPLY WITH GRADATION SHOWN ON SHEET 9 (1-1/2"). RECYCLED CONCRETE MEETING THIS GRADATION MAY BE USED.
- WIRE MESH SHALL BE FABRICATED OF 20 GAUGE WIRE TWISTED INTO A MESH WITH A MAXIMUM OPENING OF 1.0 INCH (COMMONLY TERMED "CHICKEN WIRE"). ROLL WIDTH SHALL BE 48-INCHES.
- WIRE MESH SHALL BE SECURED USING "HOG RINGS" OR WIRE TIES AT 6-INCH CENTERS ALONG ALL JOINTS AND AT 2-INCH CENTERS ON ENDS OF BERM.
- THE ENDS OF THE REINFORCED ROCK BERM SHALL BE 12" HIGHER THAN THE CENTER OF THE BERM.

MAINTENANCE NOTES

- THE DESC MANAGER SHALL INSPECT CULVERT INLET FILTER WEEKLY, DURING AND AFTER ANY STORM EVENT AND MAKE REPAIRS OR CLEAN OUT AS NECESSARY.
- SEDIMENT ACCUMULATED UPSTREAM OF CULVERT INLET FILTER SHALL BE REMOVED WHEN THE SEDIMENT DEPTH UPSTREAM OF FILTER IS 1/2 THE HEIGHT OF THE REINFORCED ROCK BERM.
- RRB FOR CULVERT PROTECTION ARE TO REMAIN IN PLACE UNTIL THE UPSTREAM DISTURBED AREA IS STABILIZED AND GRASS COVER IS APPROVED BY THE COUNTY.
- WHEN CULVERT INLET FILTERS ARE REMOVED, ANY DISTURBED AREA SHALL BE DRILL SEEDED AND CRIMP MULCHED OR OTHERWISE STABILIZED IN A MANNER APPROVED BY THE COUNTY.

SEDIMENT CONTROL LOG INSTALLATION NOTES

- SEE PLAN VIEW FOR:
 - LOCATION AND LENGTH OF SEDIMENT CONTROL LOG.
- SEDIMENT CONTROL LOGS INDICATED ON INITIAL GESC PLAN SHALL BE INSTALLED PRIOR TO ANY LAND-DISTURBING ACTIVITIES.
- SEDIMENT CONTROL LOGS SHALL CONSIST OF STRAW, COMPOST, EXCELSIOR, OR COCONUT FIBER.
- NOT FOR USE IN CONCENTRATED FLOW AREAS.
- THE SEDIMENT CONTROL LOG SHALL BE TRENCHED INTO THE GROUND A MINIMUM OF 2".

SEDIMENT CONTROL LOG MAINTENANCE NOTES

- THE DESC MANAGER SHALL INSPECT SEDIMENT CONTROL LOGS DAILY, DURING AND AFTER ANY STORM EVENT AND MAKE REPAIRS OR CLEAN OUT UPSTREAM SEDIMENT AS NECESSARY.
- SEDIMENT ACCUMULATED UPSTREAM OF SEDIMENT CONTROL LOGS SHALL BE REMOVED WHEN THE UPSTREAM SEDIMENT DEPTH IS WITHIN 1/2 THE HEIGHT OF THE CREST OF LOG.
- SEDIMENT CONTROL LOG SHALL BE REMOVED AT THE END OF CONSTRUCTION. IF ANY DISTURBED AREA EXISTS AFTER REMOVAL, IT SHALL BE DRILL SEEDED AND CRIMP MULCHED OR OTHERWISE STABILIZED IN A MANNER APPROVED BY THE COUNTY.

RRB REINFORCED ROCK BERM 8

RRC RRB FOR CULVERT PROTECTION 9

SCL SEDIMENT CONTROL LOG 10

Sheet Revisions	

NOTE: SCALES SHOWN ARE FOR 22"x34" SHEETS; ADJUST ACCORDINGLY FOR 11"x17" SHEETS.

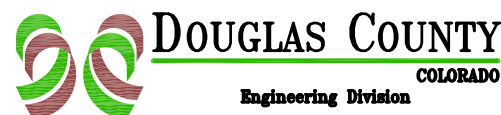

DESC DRAINAGE, EROSION, AND SEDIMENT CONTROL

DESC PLAN STANDARD NOTES AND DETAILS

SHEET 6 OF 9

SEEDING AND MULCHING INSTALLATION NOTES

1. SEE PLAN VIEW FOR:
 - AREA OF SEEDING AND MULCHING.
 - TYPE OF SEED MIX (PERMANENT, TEMPORARY, OR LOW-GROWTH).
2. ALL BRANDS FURNISHED SHALL BE FREE FROM SUCH NOXIOUS SEEDS AS RUSSIAN OR CANADIAN THISTLE, COARSE FESCUE, EUROPEAN BINDWEED, JOHNSON GRASS, Knap WEED AND LEAFY SPURGE.
3. THE SEEDER SHALL FURNISH TO THE CONTRACTOR A SIGNED STATEMENT CERTIFYING THAT THE SEED FURNISHED IS FROM A LOT THAT HAS BEEN TESTED BY A RECOGNIZED LABORATORY. SEED WHICH HAS BECOME WET, MOLDY, OR OTHERWISE DAMAGED IN TRANSIT OR IN STORAGE WILL NOT BE ACCEPTABLE. SEED TICKETS SHALL BE PROVIDED TO DOUGLAS COUNTY UPON REQUEST.
4. DRILL SEEDING MIX SHALL CONFORM TO THE TABLE ON THE RIGHT:
5. IF THE SEED AVAILABLE ON THE MARKET DOES NOT MEET THE MINIMUM PURITY AND GERMINATION PERCENTAGES SPECIFIED, THE SUBCONTRACTOR MUST COMPENSATE FOR A LESSER PERCENTAGE OF PURITY OR GERMINATION BY FURNISHING SUFFICIENT ADDITIONAL SEED TO EQUAL THE SPECIFIED PRODUCT. THE TAGS FROM THE SEED MIXES MUST BE SUPPLIED TO THE CONTRACTOR AND FORWARDED TO THE DOUGLAS COUNTY EROSION CONTROL INSPECTOR.
6. THE FORMULA USED FOR DETERMINING THE QUANTITY OF PURE LIVE SEED (PLS) SHALL BE (POUNDS OF SEED) X (PURITY) X (GERMINATION) = POUNDS OF PURE LIVE SEED (PLS).
7. PERMANENT SEED MIX SHALL BE USED UNLESS OTHERWISE APPROVED BY THE COUNTY.
8. ALL AREAS TO BE SEEDED AND MULCHED SHALL HAVE NATIVE TOPSOIL OR APPROVED SOIL AMENDMENTS SPREAD TO A DEPTH OF AT LEAST 6 INCHES (LOOSE DEPTH). HAUL ROADS AND OTHER COMPACTED AREAS SHALL BE LOOSENEED TO A DEPTH OF 6 INCHES PRIOR TO SPREADING TOPSOIL.
9. SOIL IS TO BE THOROUGHLY LOOSENEED (TILLED) TO A DEPTH OF AT LEAST 6 INCHES PRIOR TO SEEDING. THE TOP 6 INCHES OF THE SEED BED SHALL BE FREE OF ROCKS GREATER THAN 4 INCHES AND SOIL CLODS GREATER THAN 2 INCHES. SEEDING OVER ANY COMPACTED AREAS THAT HAVEN'T BEEN THOROUGHLY LOOSENEED SHALL BE REJECTED.
10. SEED IS TO BE APPLIED USING A MECHANICAL DRILL TO A DEPTH OF 1/4 INCH. ROW SPACING SHALL BE NO MORE THAN 6 INCHES. MATERIAL USED FOR MULCH SHALL CONSIST OF LONG-STEMMED STRAW. AT LEAST 50 PERCENT OF THE MULCH, BY WEIGHT, SHALL BE 10 INCHES OR MORE IN LENGTH. MULCH SHALL BE APPLIED AND MECHANICALLY ANCHORED TO A DEPTH OF AT LEAST 2 INCHES. MULCH SHALL BE APPLIED AT A RATE OF 4000 LB. OF STRAW PER ACRE.
11. IF THE PERMITTEE DEMONSTRATES TO THE COUNTY THAT IT IS NOT POSSIBLE TO DRILL SEED, SEED IS TO BE UNIFORMLY BROADCAST AT TWO TIMES THE DRILLED RATE, THEN LIGHTLY HARROWED TO PROVIDE A SEED DEPTH OF APPROXIMATELY 1/4 INCH, THEN ROLLED TO COMPACT, THEN MULCHED AS SPECIFIED ABOVE.
12. SEEDING AND MULCHING SHALL BE COMPLETED WITHIN 30 DAYS OF INITIAL EXPOSURE OR 14 DAYS AFTER GRADING IS SUBSTANTIALLY COMPLETE IN A GIVEN AREA (AS DEFINED BY THE COUNTY). THIS MAY REQUIRE MULTIPLE MOBILIZATIONS FOR SEEDING AND MULCHING.
13. MULCH SHALL BE APPLIED WITHIN 24-HOURS OF SEEDING.
14. TACKIFIER SHOULD BE UTILIZED TO HELP WITH STRAW DISPLACEMENT.

SEEDING AND MULCHING MAINTENANCE NOTES

1. SEEDED AND MULCHED AREAS SHALL BE INSPECTED FOR REQUIRED COVERAGE MONTHLY FOR A PERIOD OF TWO YEARS FOLLOWING INITIAL SEEDING. REPAIRS AND RE-SEEDING AND MULCHING SHALL BE UNDERTAKEN AFTER THE FIRST GROWING SEASON FOR ANY AREAS FAILING TO MEET THE REQUIRED COVERAGE.
2. REQUIRED COVERAGE FOR STANDARD, OPEN SPACE AND LOW GROWTH SEED MIXES SHALL BE DEFINED AS FOLLOWS:
 1. THREE (3) PLANTS PER SQUARE FOOT WITH A MINIMUM HEIGHT OF 3 INCHES. THE 3 PLANTS PER SQUARE FOOT SHALL BE OF THE VARIETY AND SPECIES FOUND IN THE DOUGLAS COUNTY-APPROVED MIX.
 2. NO BARE AREAS LARGER THAN 4 SQUARE FEET (TWO- FEET BY TWO- FEET OR EQUIVALENT).
 3. FREE OF ERODED AREAS.
 4. FREE FROM INFESTATION OF NOXIOUS WEEDS IN ACCORDANCE WITH SECTION 6.4 OF THE GESC MANUAL.
3. REQUIRED COVERAGE FOR TURF GRASS AREAS SHALL BE DEFINED AS FOLLOWS:
 1. AT LEAST 80% VEGETATIVE COVER OF GRASS SPECIES PLANTED.
 2. NO BARE AREAS LARGER THAN 4 SQUARE FEET (TWO- FEET BY TWO- FEET OR EQUIVALENT).
 3. FREE OF ERODED AREAS.
 4. FREE FROM INFESTATION OF NOXIOUS WEEDS IN ACCORDANCE WITH SECTION 6.4 OF THE GESC MANUAL.
4. RILL AND GULLY EROSION SHALL BE FILLED WITH TOPSOIL PRIOR TO RESEEDING. THE RESEEDING METHOD SHALL BE APPROVED BY THE COUNTY.

DOUGLAS COUNTY PERMANENT DRILL SEEDING MIX

SPECIES	VARIETY	NOTES	% IN MIX	POUNDS OF PLS PER ACRE
BIG BLUESTEM	KAW	PNWS	10	1.1
YELLOW INDIANGRASS	CHEYENNE	PNWS	10	1
SWITCHGRASS	BLACKWELL	PNWS	10	0.4
SIDEOATS GRAMA	VAUGHN	PNWB	10	0.9
WESTERN WHEATGRASS	ARRIBA	PNCS	10	1.6
BLUE GRAMA	HACHITA	PNWB	10	0.3
THICKSPIKE WHEATGRASS	CRITANA	PNCS	10	1
PRAIRIE SANDREED	GOSHEN	PNWS	10	0.7
GREEN NEEDLEGRASS	LODORM	PNCB	10	1
SLENDER WHEATGRASS	PRYOR	PNCB	5	0.6
STREAMBANK WHEATGRASS	SODAR	PNCS	5	0.6
TOTAL				9.2

DOUGLAS COUNTY TEMPORARY DRILL SEEDING MIX

SPECIES	VARIETY	NOTES	% IN MIX	POUNDS OF PLS PER ACRE
SMOOTH BROMEGRASS	LINCOLN	PICS	30	3.9
INTERMEDIATE WHEATGRASS	OAHE	PICS	30	4.5
PUBESCENT WHEATGRASS	LUNA	PICS	30	4.2
ANNUAL RYEGRASS	N/A	AICB	10	0.8
TOTAL				13.4

DOUGLAS COUNTY LOW-GROWTH DRILL SEEDING MIX

SPECIES	VARIETY	NOTES	% IN MIX	POUNDS OF PLS PER ACRE
BUFFALOGRASS	TEXOKA	PNWS	20	3.2
BLUE GRAMA	HACHITA	PNWB	20	0.6
WESTERN WHEATGRASS	ARRIBA	PNCS	20	3.2
SIDEOATS GRAMA	VAUGHN	PNWB	20	1.8
THICKSPIKE WHEATGRASS	CRITANA	PNCS	10	1
STREAMBANK WHEATGRASS	SODAR	PNCS	10	1.2
TOTAL				11.0

NOTES:
 P=PERENNIAL
 A=ANNUAL
 N=NATIVE
 I=INTRODUCED
 W=WARM SEASON
 C=COOL SEASON
 S=SOD FORMER
 B=BUNCHGRASS

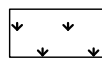

SM SEEDING AND MULCHING 11

Sheet Revisions	

NOTE: SCALES SHOWN ARE FOR 22"x34" SHEETS; ADJUST ACCORDINGLY FOR 11"x17" SHEETS.

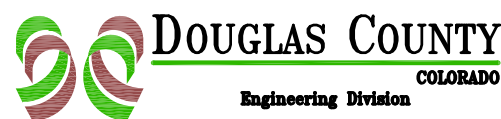

DESC DRAINAGE, EROSION, AND SEDIMENT CONTROL

DESC PLAN STANDARD NOTES AND DETAILS

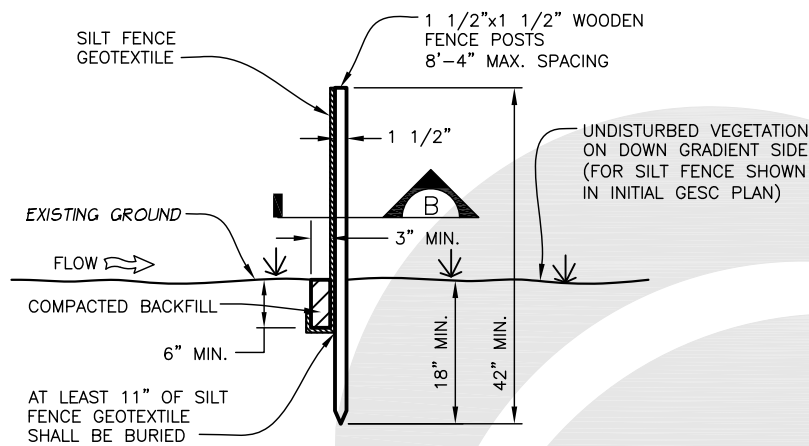

ELEVATION
SCALE: 1" = 1'-0"

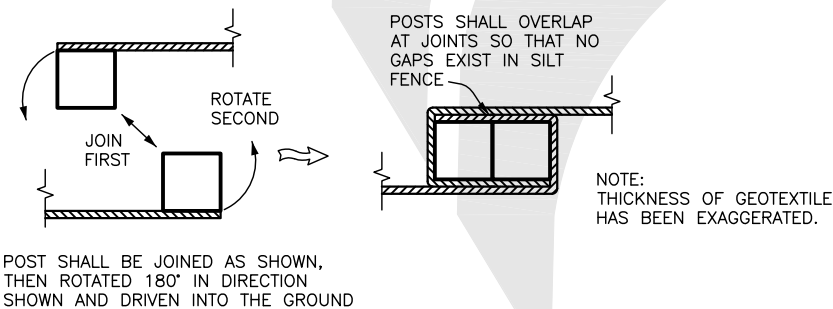

JOINTS - SECTION B
SCALE: N.T.S.

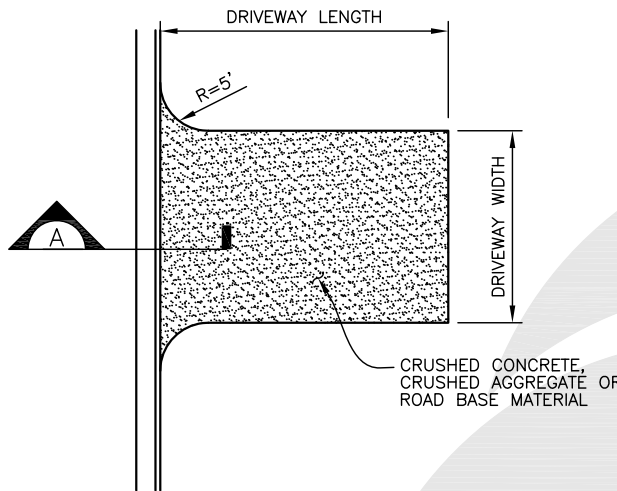

PLAN
SCALE: 1" = 10'-0"

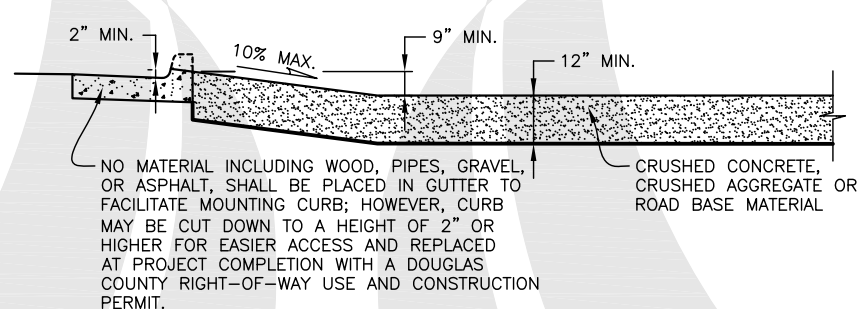

SECTION A
SCALE: 1/2" = 1'-0"

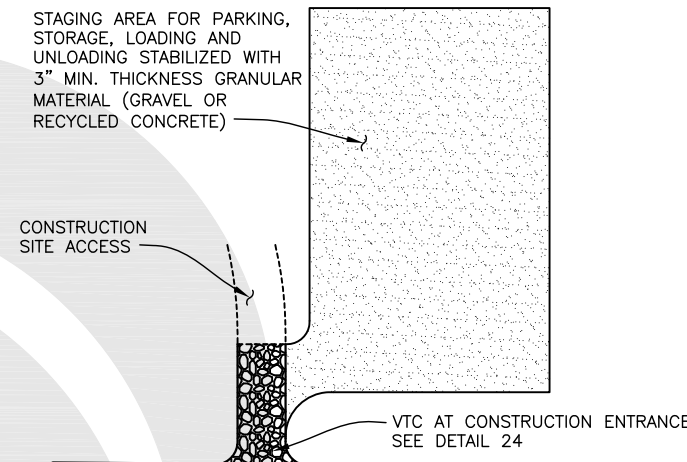

PLAN
SCALE: 1" = 40'-0"

STABILIZED STAGING AREA INSTALLATION NOTES

1. SEE PLAN VIEW FOR GENERAL LOCATION OF STAGING AREA. CONTRACTOR MAY MODIFY LOCATION AND SIZE OF STABILIZED STAGING AREA WITH COUNTY APPROVAL.
2. STABILIZED STAGING AREA SHALL BE LARGE ENOUGH TO FULLY CONTAIN PARKING, STORAGE, AND UNLOADING AND LOADING OPERATIONS.
3. IF REQUIRED BY THE COUNTY, SITE ACCESS ROADS SHALL BE STABILIZED IN THE SAME MANNER AS THE STAGING AREA.
4. STAGING AREA SHALL BE STABILIZED PRIOR TO ANY OTHER OPERATIONS ON THE SITE.
5. THE STABILIZED STAGING AREA SHALL CONSIST OF A MINIMUM OF 3" OF GRANULAR MATERIAL (GRAVEL OR RECYCLED CONCRETE).

STABILIZED STAGING AREA MAINTENANCE NOTES

1. THE DESC MANAGER SHALL INSPECT THE STABILIZED STAGING AREA WEEKLY, DURING AND AFTER ANY STORM EVENT AND MAKE REPAIRS OR CLEAN OUT UPSTREAM SEDIMENT AS NECESSARY.
2. DESC MANAGER SHALL PROVIDE ADDITIONAL THICKNESS OF GRANULAR MATERIAL IF ANY RUTTING OCCURS OR UNDERLYING SUBGRADE BECOMES EXPOSED.
3. STABILIZED STAGING AREA SHALL BE ENLARGED IF NECESSARY TO CONTAIN PARKING, STORAGE, AND UNLOADING AND LOADING OPERATIONS.
4. ANY ACCUMULATED DIRT OR MUD SHALL BE REMOVED FROM THE SURFACE OF THE STABILIZED STAGING AREA.
5. THE STABILIZED STAGING AREA SHALL BE REMOVED AT THE END OF CONSTRUCTION. THE GRANULAR MATERIAL SHALL BE REMOVED OR, IF APPROVED BY THE COUNTY, USED ON SITE, AND THE AREA TOPSOILED, DRILL SEEDED AND CRIMP MULCHED OR OTHERWISE STABILIZED.

STABILIZED DRIVEWAY ACCESS INSTALLATION NOTES

1. STABILIZED DRIVEWAY ACCESS SHALL BE INSTALLED AT EVERY ACCESS POINT TO SITE.
2. A STABILIZED DRIVEWAY ACCESS SHALL CONSIST OF CRUSHED CONCRETE, CRUSHED AGGREGATE, OR ROAD BASE MATERIAL IN THE SAME LOCATION AS FUTURE PERMANENT DRIVEWAY. TYPICALLY THE MATERIAL USED TO STABILIZE THE SUBGRADE PRIOR TO POURING A DRIVEWAY IS SUFFICIENT.
3. ANY CRACKED OR DAMAGED CURB AND GUTTER AND SIDEWALK SHALL BE REPLACED BY PERMITTEE.

STABILIZED DRIVEWAY ACCESS MAINTENANCE NOTES

1. DESC MANAGER SHALL INSPECT STABILIZED DRIVEWAY ACCESS DAILY. GRAVEL SURFACE SHALL BE CLEAN AND LOOSE ENOUGH TO RUT SLIGHTLY UNDER WHEEL LOADS AND CAUSE LOOSE GRAVEL TO DISLodge MUD FROM TIRES. WHEN GRAVEL BECOMES COMPACTED OR FILLED WITH SEDIMENT SO THAT THE EFFECTIVENESS OF THE PAD IS DIMINISHED, CONTRACTOR SHALL RIP, TURN OVER, OR OTHERWISE LOOSEN MATERIAL, PLACE ADDITIONAL NEW MATERIAL, OR REPLACE WITH NEW MATERIAL AS NECESSARY TO RESTORE EFFECTIVENESS.
2. STABILIZED DRIVEWAY ACCESS SHALL TYPICALLY BE USED TO STABILIZE THE SUBGRADE PRIOR TO POURING A DRIVEWAY.

SILT FENCE INSTALLATION NOTES

1. SEE PLAN VIEW FOR:
 - LOCATION AND LENGTH OF FENCE.
2. ANCHOR TRENCH SHALL BE EXCAVATED WITH TRENCHER, OR WITH SILT FENCE INSTALLATION MACHINE; NO ROAD GRADERS, BACKHOES, ETC. SHALL BE USED. TRENCH SHALL BE COMPACTED BY HAND, WITH "JUMPING JACK", OR BY WHEEL ROLLING. COMPACTION SHALL BE SUCH THAT SILT FENCE RESISTS BEING PULLED OUT OF ANCHOR TRENCH BY HAND.
3. SILT FENCE GEOTEXTILE SHALL MEET THE FOLLOWING REQUIREMENTS:
 - 6-TO 12-GALLONS PER MINUTE PER SQUARE FOOT FLOW CAPACITY.
 - 90 LB. TENSILE STRENGTH PER ASTM D4622.
 - UV DESIGN AT 500 HRS MIN. 70% STRENGTH RETAINED PER ASTM D4355.
4. SILT FENCE INDICATED ON INITIAL GESC PLAN SHALL BE INSTALLED PRIOR TO ANY LAND-DISTURBING ACTIVITIES.

SILT FENCE MAINTENANCE NOTES

1. THE DESC MANAGER SHALL INSPECT SILT FENCE DAILY, DURING AND AFTER ANY STORM EVENT AND MAKE REPAIRS OR CLEAN OUT UPSTREAM SEDIMENT AS NECESSARY.
2. SEDIMENT ACCUMULATED UPSTREAM OF SILT FENCE SHALL BE REMOVED WHEN THE UPSTREAM SEDIMENT REACHES A DEPTH OF 6-INCHES.
3. SILT FENCE SHALL BE REMOVED WHEN THE UPSTREAM DISTURBED AREA IS STABILIZED AND GRASS COVER IS APPROVED BY THE COUNTY. IF ANY DISTURBED AREA EXISTS AFTER REMOVAL, IT SHALL BE SEEDED AND MULCHED OR OTHERWISE STABILIZED IN A MANNER APPROVED BY THE COUNTY.

SF SILT FENCE **12**

SDA STABILIZED DRIVEWAY ACCESS **13**

SSA STABILIZED STAGING AREA **14**

C:\Land Projects\2009\GESC_Mannual.dwg\DESC Details 1-9.dwg, 1/10/2013 10:50:31 AM, 1:2

Sheet Revisions	

NOTE: SCALES SHOWN ARE FOR 22"x34" SHEETS; ADJUST ACCORDINGLY FOR 11"x17" SHEETS.

DESC DRAINAGE, EROSION, AND SEDIMENT CONTROL

DESC PLAN STANDARD NOTES AND DETAILS

SHEET 8 OF 9

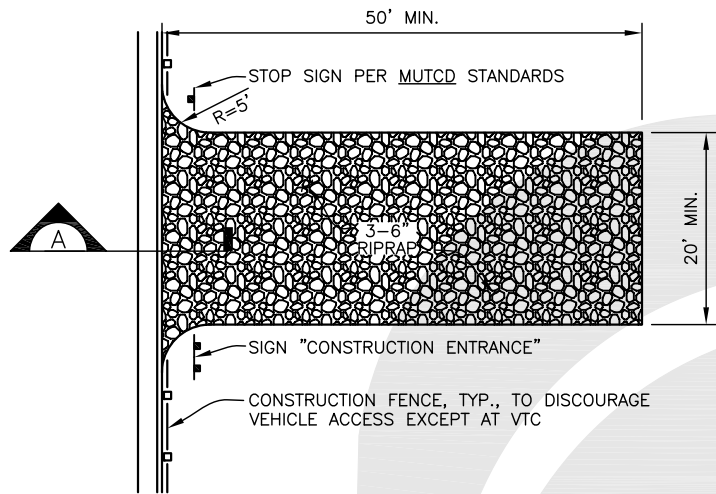

PLAN

SCALE: 1" = 10'-0"

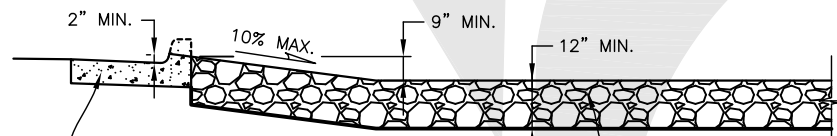

SECTION A

SCALE: 1/2" = 1'-0"

NO MATERIAL INCLUDING WOOD, PIPES, GRAVEL, OR ASPHALT, SHALL BE PLACED IN GUTTER TO FACILITATE MOUNTING CURB; HOWEVER, CURB MAY BE CUT DOWN TO A HEIGHT OF 2" OR HIGHER FOR EASIER ACCESS AND REPLACED AT PROJECT COMPLETION WITH A DOUGLAS COUNTY RIGHT-OF-WAY USE AND CONSTRUCTION PERMIT; DOUGLAS COUNTY TEMPORARY CONSTRUCTION ACCESS PERMIT IS REQUIRED FOR ALL VTCs

3-6" RIPRAP
SEE SHEET 1
FOR GRADATION

VEHICLE TRACKING CONTROL INSTALLATION NOTES

1. VEHICLE TRACKING CONTROL PADS SHALL BE INSTALLED AT EVERY ACCESS POINT TO SITE.
2. VEHICLE TRACKING CONTROL PADS SHALL CONSIST OF HARD, DENSE, DURABLE STONE, ANGULAR IN SHAPE AND RESISTANT TO WEATHERING. ROUNDED STONE OR BOULDERS WILL NOT BE ACCEPTABLE. THE STONES SHALL BE 3" WITH A MAXIMUM SIZE OF 6". THE STONE SHALL HAVE A SPECIFIC GRAVITY OF AT LEAST 2.6. CONTROL OF GRADATION WILL BE BY VISUAL INSPECTIONS.
3. ANY CRACKED OR DAMAGED CURB AND GUTTER AND SIDEWALK SHALL BE REPLACED BY PERMITTEE.
4. A STOP SIGN INSTALLED IN ACCORDANCE WITH THE MANUAL ON UNIFORM TRAFFIC CONTROL DEVICES (MUTCD), AS AMENDED, SHALL BE INSTALLED FOR EXITING TRAFFIC AT THE VTC.

VEHICLE TRACKING CONTROL MAINTENANCE NOTES

1. DESC MANAGER SHALL INSPECT VEHICLE TRACKING CONTROL DAILY. GRAVEL SURFACE SHALL BE CLEAN AND LOOSE ENOUGH TO RUT SLIGHTLY UNDER WHEEL LOADS AND CAUSE LOOSE GRAVEL TO DISLODGE MUD FROM TIRES. WHEN GRAVEL BECOMES COMPACTED OR FILLED WITH SEDIMENT SO THAT THE EFFECTIVENESS OF THE PAD IS DIMINISHED, CONTRACTOR SHALL RIP, TURN OVER, OR OTHERWISE LOOSEN GRAVEL, PLACE ADDITIONAL NEW GRAVEL, OR REPLACE WITH NEW GRAVEL AS NECESSARY TO RESTORE EFFECTIVENESS.
2. VEHICLE TRACKING CONTROL SHALL BE REMOVED AT THE END OF CONSTRUCTION, THE GRAVEL MATERIAL REMOVED OR, IF APPROVED BY THE COUNTY, USED ON SITE, AND THE AREA TOPSOILED, DRILL SEEDED AND CRIMP MULCHED OR OTHERWISE STABILIZED.



VTC VEHICLE TRACKING CONTROL 15

ROCK AND RIPRAP GRADATIONS

TABLE 1. RIPRAP GRADATIONS

D50 MEDIAN STONE SIZE (INCHES)	% OF MATERIAL SMALLER THAN TYPICAL STONE	TYPICAL STONE EQUIVALENT DIAMETER (INCHES)	TYPICAL STONE WEIGHT (POUNDS)
6	70 - 100	12	85
	50 - 70	9	35
	35 - 50	6	10
	2 - 10	2	0.4
9	70 - 100	15	160
	50 - 70	12	85
	35 - 50	9	35
	2 - 10	3	1.3
12	70 - 100	21	440
	50 - 70	18	275
	35 - 50	12	85
	2 - 10	4	3
18	100	30	1280
	50 - 70	24	650
	35 - 50	18	275
	2 - 10	6	10
24	100	42	3500
	50 - 70	33	1700
	35 - 50	24	650
	2 - 10	9	35

TABLE 2. RIPRAP BEDDING

SIEVE SIZE	MASS PERCENT PASSING SQUARE MESH SIEVES
	CLASS A
3"	100
1 1/2"	20 - 90
NO. 4	0 - 20
NO. 200	0 - 3

MATCHES SPECIFICATIONS FOR CDOT CLASS A FILTER MATERIAL AND UDFCD TYPE 1 BEDDING. ALL ROCK SHALL BE FRACTURED FACE, ALL SIDES.

TABLE 3. 1 1/2" CRUSHED ROCK

SIEVE SIZE	MASS PERCENT PASSING SQUARE MESH SIEVES
	NO. 4
2"	100
1 1/2"	90 - 100
1"	20 - 55
3/4"	0 - 15
3/8"	0 - 5

MATCHES SPECIFICATIONS FOR NO. 4 COARSE AGGREGATE FOR CONCRETE PER AASHTO M43. ALL ROCK SHALL BE FRACTURED FACE, ALL SIDES.

Sheet Revisions	

NOTE: SCALES SHOWN ARE FOR 22"x34" SHEETS; ADJUST ACCORDINGLY FOR 11"x17" SHEETS.

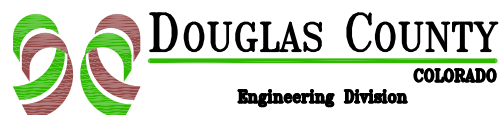

DESC DRAINAGE, EROSION, AND SEDIMENT CONTROL

DESC PLAN STANDARD NOTES AND DETAILS

SHEET 9 OF 9